

版本 REV.	日期 DATE	ECN NO.	变更内容 DESCRIPTION	制图 DRAWN

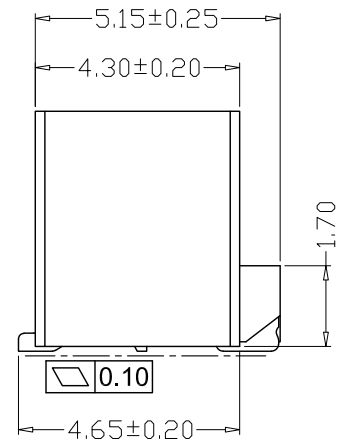
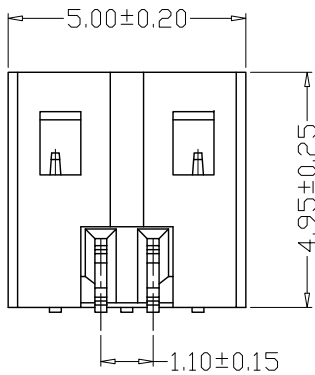
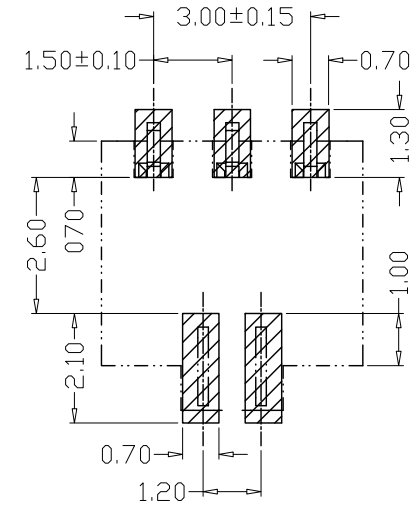
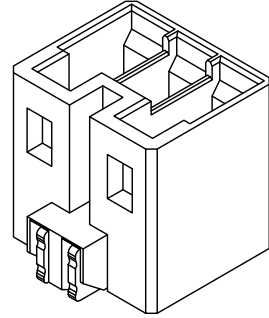
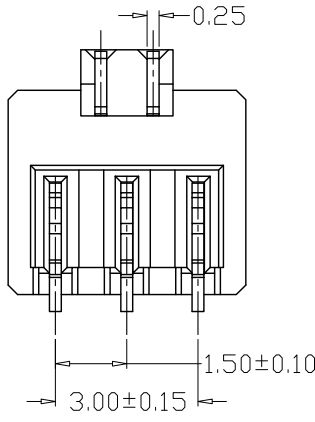

PCB LAYOUT

SPECIFICATIONS

- 1、Current Rating: 1A AC, DC
- 2、Voltage Rating: 250V AC, DC
- 3、Temperatuer Range: -25°C~+130°C
- 4、Contact Resistance: 20mΩ Max
- 5、Insulation Resistance: 1000MΩ Min
- 6、Withstanding Voltang: 1500V AC/minute
- 7、Material

Wafer: PA6T UL94V-0
 PIN: Brass Tin-plated
 Fixed piece: Phosphoric bronze Tin-plated

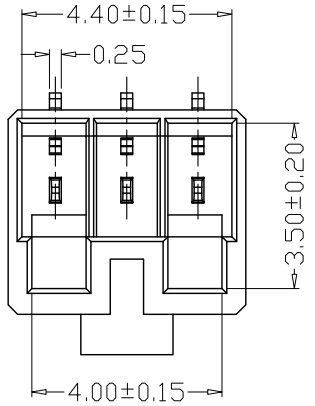

GENERAL TOLERANCE		制图 Mapping	张迎春 2022、09、02	料号 PART NO.	B15012-03AB	版本 REV.	A
X±0.25	X*±2'	审核 Audit	钱岳生 2022、09、02	品名 TITLE	1560立贴 WAFER SMT TYPE	页次 SHEET	1/1
.X±0.20	.X*±1'	核准 Approved	张名 2022、09、03	客户料号 CUTM. NO.			
.XX±0.15	.XX*±0.5'	单位 Units	MM	比例 SCALE	1:1		
.XXX±0.10	.XXX*±0.5'			乐清市宏一电子有限公司 Yueqing HongYi Electronics Co., Ltd			